



Sewing Patterns – Level 1

Know Your Tools

Skills learned during this project:

Using Sewing Equipment
Using a Sewing Machine
Pressing fabric and seams,
Straight Stitching
Finish edge of seam allowance with a zig-zag stitch

Discovery:

Demonstrate your understanding of the following tools and techniques:

- ___ Learn the names and uses for the different parts of your sewing machine.
- ___ Obtain basic sewing tools: Scissors, pins, pin cushion, tape measure, assorted hand needles, seam ripper
- ___ Explain the purpose of the following tools: Iron, press cloth, 6" ruler or hem gauge, tracing wheel and paper, chalk pencil, pinking shears, rotary cutter with mat and ruler
- ___ Practice winding a bobbin on your machine. Make 3 bobbins of 3 different colors
- ___ Practice threading your machine. Use a bobbin color to match the top thread.
- ___ Sew a straight stitch on sample piece of fabric. Lengthen the stitch to the longest stitch length and sew another line.
- ___ With a different color of thread sew a zig-zag line down your piece of scrap fabric.
- ___ Make a small, medium and large zig-zag by adjusting your stitch regulator
- ___ With a different color of thread, try sewing the other stitches available on your machine
- ___ Put two pieces of scrap fabric together (cut them to the same size). Stitch a seam along the 5/8" marking on your machine. Press the seam open with an iron.
- ___ Put two more pieces of fabric together. Sew a 5/8" seam. Sew a zig-zag stitch along each single piece of the seam allowance. This step will create a finish on fabrics that ravel easily.
- ___ Optional: Follow the instructions below to make a pillow case or nine-square pillow

Basic Sewing Machine Parts: Most sewing machines have a spool pin and bobbin winder shaft on the top of the machine. Check your owner's manual.

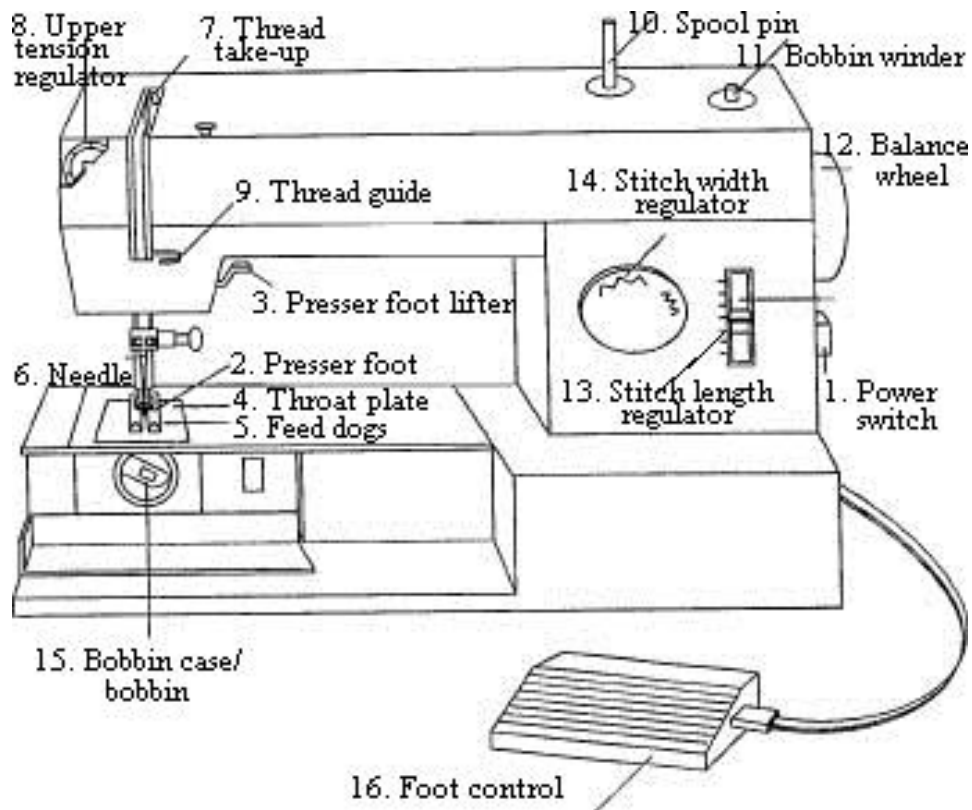

Parts of a sewing machine

Instructions- Nine Square Pillow

Step 1: Buy fabric or use some scrap fabric at home. 1/4 yard to two coordinating pieces of fabric for front, plus 1/2 yard of fabric for back. Buy fiber fill or a pillow form to stuff the pillow. Finished pillow is about 12" x 12'

Step 2: Cut nine squares of fabric on the grain line. (5" x 5") Cut 4 of one color and 5 of the other color.

Step 3: Pin the right sides of two squares together. Sew a 5/8" seam along one side. Add a third square to make a row and sew another seam.

Step 4: Sew two more rows of three squares in each row.

Step 5: Press Seam Allowances open.

Step 6: Pin and sew two rows together. Add the third row and your pillow top is complete.

Step 7: Cut a back for your pillow that is the same size as the top.

Step 8: Put right sides together of pillow top and back. Sew around the edge, leaving a 4-5" space in the middle of a seam to turn your pillow right side out.

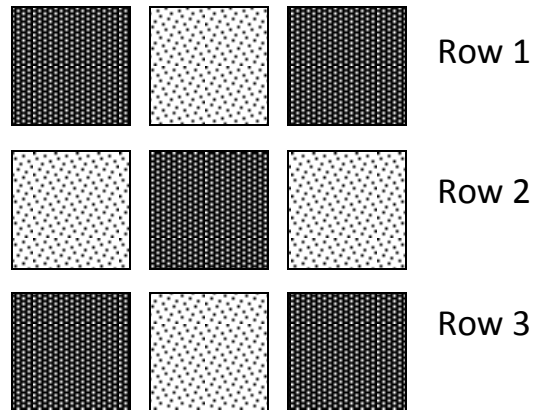

You can stuff your pillow with fiberfill, or you can use a pillow form. If you use a pillow form, leave one completely open before turning the fabric inside out.

After your pillow is stuffed, you can slipstitch the space together using a hand sewing needle and thread.

Instructions - Pillowcase

Materials Needed:

3/4 yard woven fabric

1/4 yard coordinating fabric

Step 1: Wash fabric before you cut it out. Cut out larger piece of fabric by folding the fabric in half with selvage edge together. Draw a line from fold to selvage at a perfect right angle on each edge of fabric. Trim excess fabric. You should have a folded rectangle (22" x 26")

Step 2: Follow the same procedure for the smaller piece of fabric. You should have a folded rectangle (22" x 8-9")

Step 3: Fold larger rectangle in half with right sides together and selvage edges together. Sew across bottom and one side. (5/8" seam)

Step 4: Trim seam allowance to 1/4" and zigzag both sides of the seam allowance together. Selvage edge does not need to be trimmed or zigzagged.

Step 5: Fold smaller rectangle in half, right sides together and selvage edges together. Press seam allowance open.

Step 6: You should have a tube of fabric. Fold the tube in half, lengthwise with wrong sides together and press. This will form the bottom band of your pillow case

Step 7: Sew the band onto the bottom of the pillow case with a 5/8" seam. Make sure the seam allowance is on the inside of the pillowcase.

Step 8: Zigzag or serge the raw edge of the seam allowance together and press.

